

Design Note

GT-NUCL1633K1

Version 1.1

May 19, 2022

Revision History

Version	Date	Description
1.0	Mar 18,2022	Created
1.1	May 19,2022	

Table of content

Revision History.....	2
Table of content.....	3
1. General Description.....	4
1.1 About this document.....	4
1.2 Related documents and reference.....	4
2. System Integration.....	5
2.1 Fingerprint module diagram.....	5
2.2 Pin description.....	5
2.3 Interface design	6-7
3. System mechanism design.....	8
3.1 System mechanism structure and specification.....	8
3.2 Mechanism assembly and positioning instructions.....	9

1. General Description

1.1. About this document

The document is created to post-system design for the GT-NUCL1633K1 embedded system.

1.2. Related documents and reference

-GT-NUCL1633K1 product specification

2. System Integration

2.1 Fingerprint module diagram

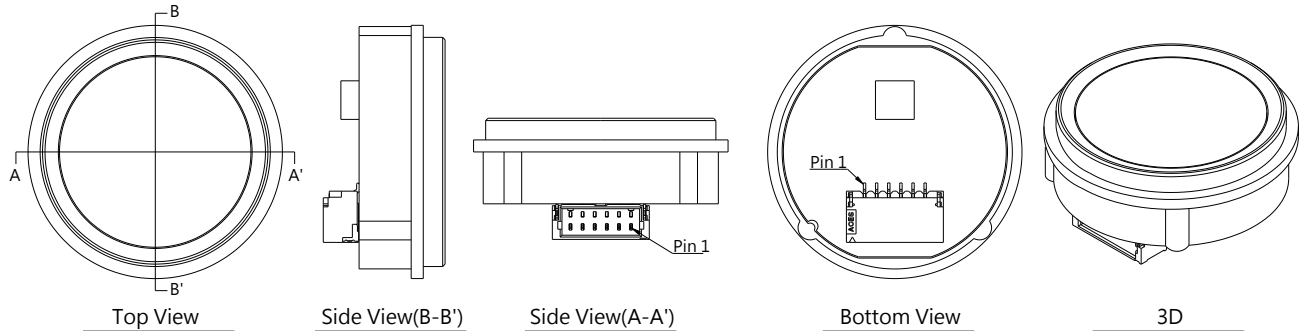

2.2 Pin description

Pin	Name	Pin Type	Function Description
1	GND	Supply	Ground
2	UART0_RXD	Input	UART data Input
3	UART0_TXD	Output	UART data Output
4	CON_3V3	Supply	Fingerprint power 3.3V(typ.).The host should be turned off the power supply to save power consumption after the fingerprint device processing cycle ends.
5	TP_high	Output	Touch signal output (active high). When the touch is working normally, it detects that a finger is placed on the fingerprint collection area of the sensor, TP_high will output a high level signal and keep it until the finger leaves.
6	TP_3V3	Supply	Touch power 3.3V(typ.). If the touch function is required, the power supply must be continuous.

2.3 Interface design

- 2.3.1 CON_3V3 provides 3.3V power supply for the fingerprint module; in order to save power consumption, the host computer manages the power supply of the module, and the power-on time should be greater than 100ms to ensure stable operation of the module. CON_3V3 should be turned off after a fingerprint module processing duty cycle.
- 2.3.2 TP_3V3 provides power for the touch module of the fingerprint module. If the touch wake-up function is required, it needs to be powered frequently. The power supply voltage of TP3V3 provides 3.3V.
- 2.3.3 TP_high: Touch sensor output pin, when the touch is working normally, it detects that a finger is placed in the fingerprint collection area of the sensor, TP_high will output a high level, and keep it until the finger leaves, the most common output time is 60sec.
- 2.3.4 Requirements for external power supply: externally provide CON3V3 and TP3V3 power supply ripple peak-to-peak (VPPmax) should be less than 50mV.
- 2.3.5 UART: The fingerprint module has a standard UART interface to communicate with the host computer. The default serial transmission rate is 115200bps, 1 start bit, 1 stop bit, 3.3VTTL level. If you need to connect with the serial port of the PC, you need to connect the TTL-RS232 adapter board to communicate.
- 2.3.6 The host computer can reduce power consumption by controlling the 3.3V power supply to be turned off. The reference circuit is shown in the figure below. The function of the upper left circuit is to control the Q2 transistor to be turned on and off through the PWR_ON/OFF signal of the MCU of the external host computer, thereby reducing the power consumption of the circuit. When the 3.3V power supply is cut off, the entire module has only the touch in the detection mode, and the power consumption is less than 5 μ A.

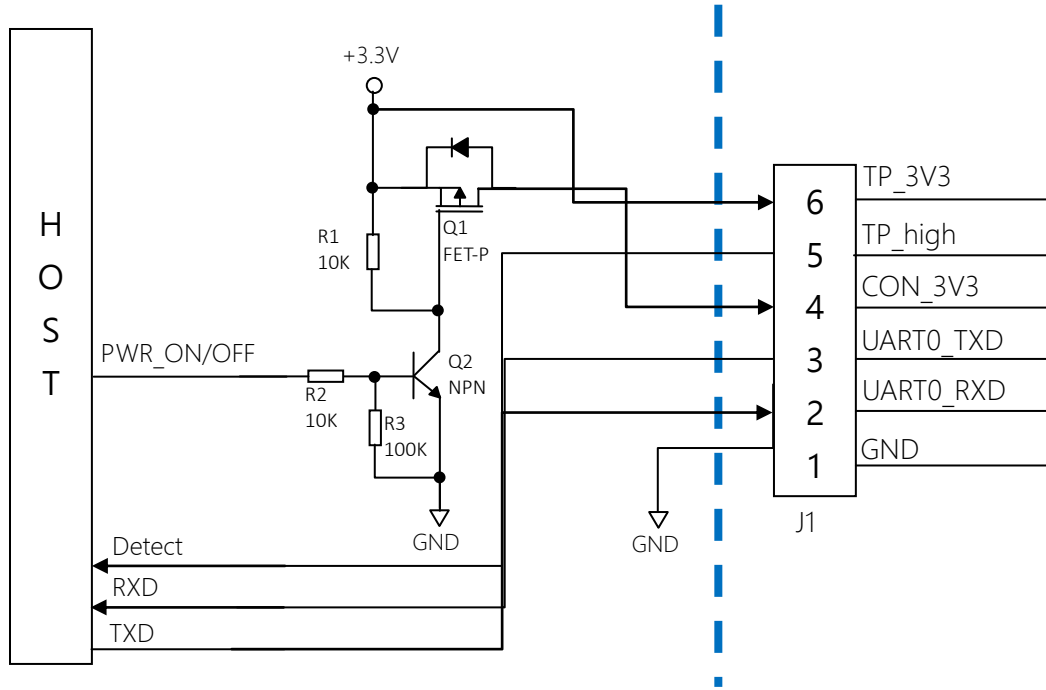

Host circuit

Finger print module

3. System mechanism design

3.1 System mechanism structure and specification

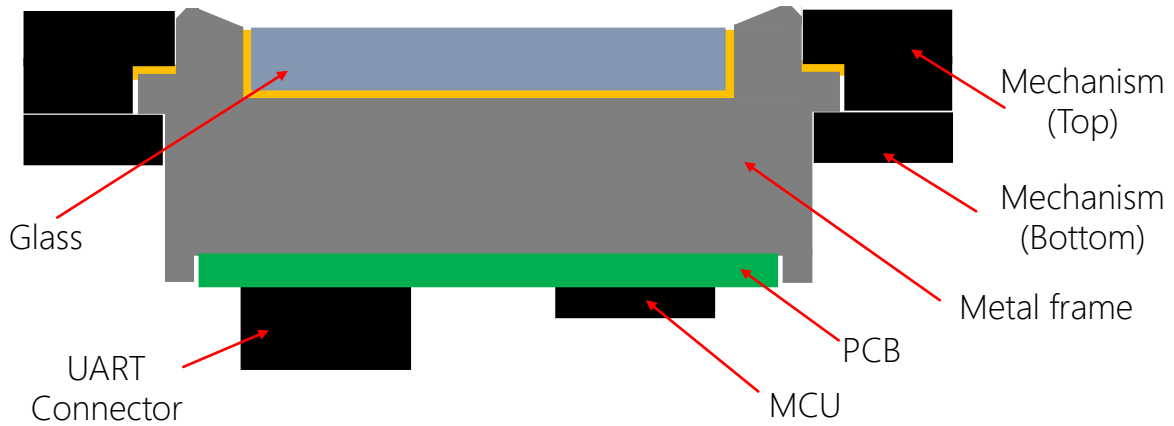

Construction	Specification
Glass	Thickness : 1.8 ± 0.1 mm Hardness (pencil) : 9H
Metal frame	Material : Aluminum alloy Thickness : 7.2 ± 0.2 mm
PCB	Thickness : 0.8 ± 0.1 mm Layer : 4 layer

3.2 Module mechanism assembly and positioning instructions

3.2.1 The fingerprint module is provided with directional positioning by three half-cylinder in the outer mechanism of the metal frame, and the upper waterproof seal is made with waterproof sealant (or film). The slashed part provides the fixed area under the rear end system where the mechanism can be pressed. It is suggested that the PCB can increase the support area (refer to the PCB support area in the figure below) to avoid the loosening of the structure caused by the pulling of the UART cable.

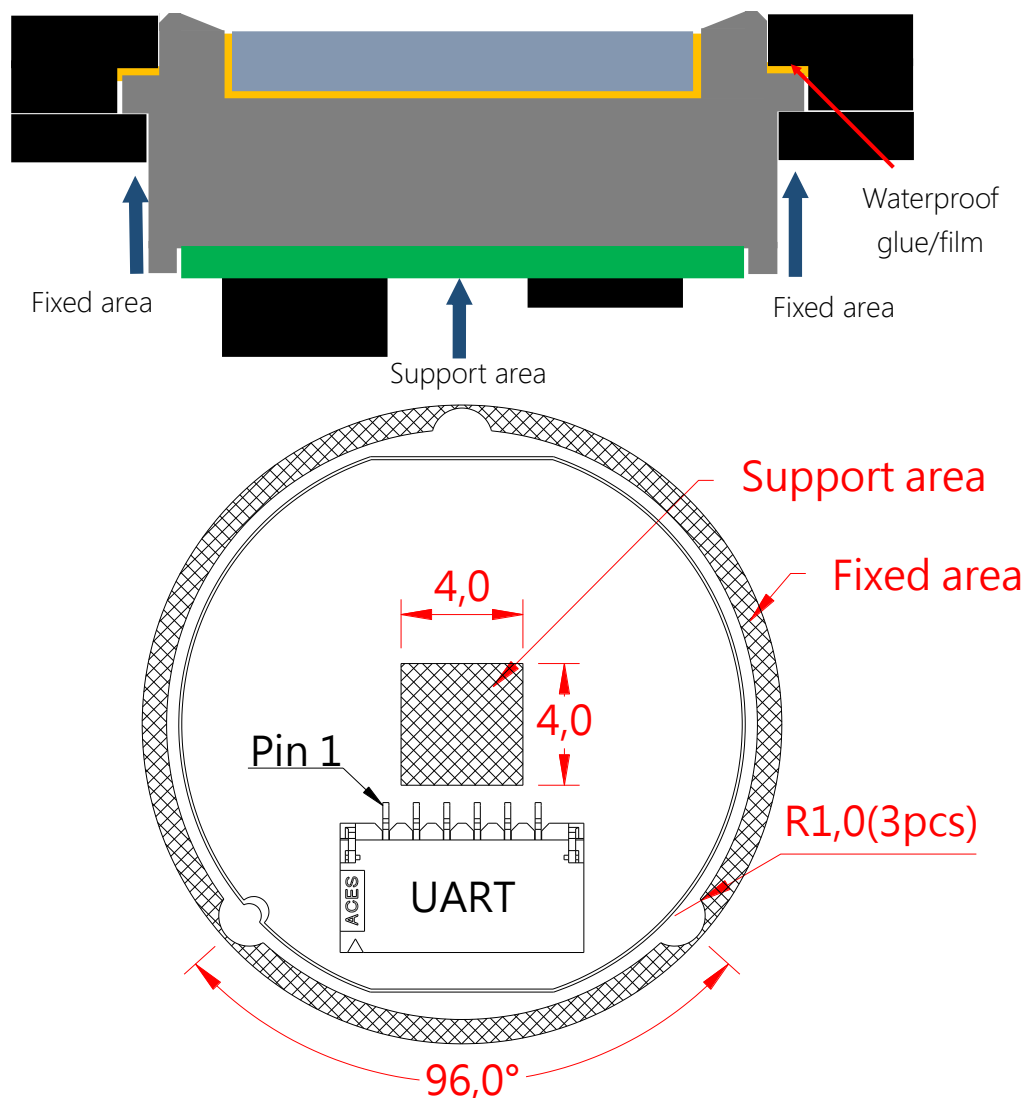

3.2.2 The module positioning support area must not have conductive contact.

3.2.3 The module positioning support needs to be balanced, and cannot be supported on one side to avoid tilting and shaking during assembly and finger pressing.